



FIA FORMULA 1 WORLD CHAMPIONSHIP



2024 AZERBAIJAN GRAND PRIX

13 - 15 September 2024

From	The FIA Formula One Media Delegate	Document	9
To	All Teams, All Officials	Date	13 September 2024
		Time	10:52

Title Car Presentation Submissions

Description Car Presentation Submissions

Enclosed 2024 Azerbaijan Grand Prix - Car Presentation Submissions.pdf

Roman De Lauw

The FIA Formula One Media Delegate



FIA FORMULA 1 WORLD CHAMPIONSHIP



Car Presentation – Azerbaijan Grand Prix Red Bull Racing

	Updated component	Primary reason for update	Geometric differences compared to previous version	Brief description on how the update works (min 20, max 100 words)
1	Floor Body	Performance - Flow Conditioning	Floor tunnel geometry subtly revised by locally raising or lowering the surfaces.	Changes applied to improve the pressure gradients along the floor to improve the flow locally and downstream in all conditions.



FIA FORMULA 1 WORLD CHAMPIONSHIP

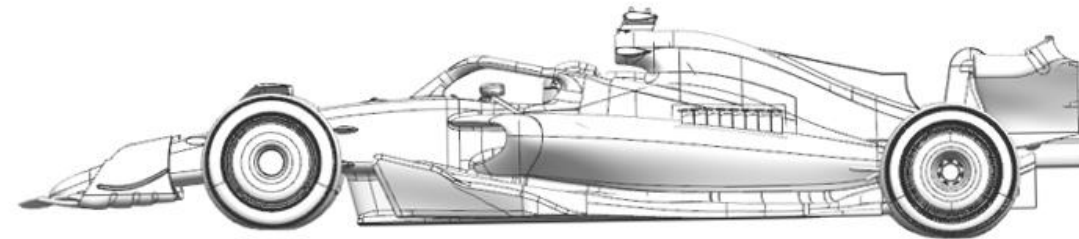
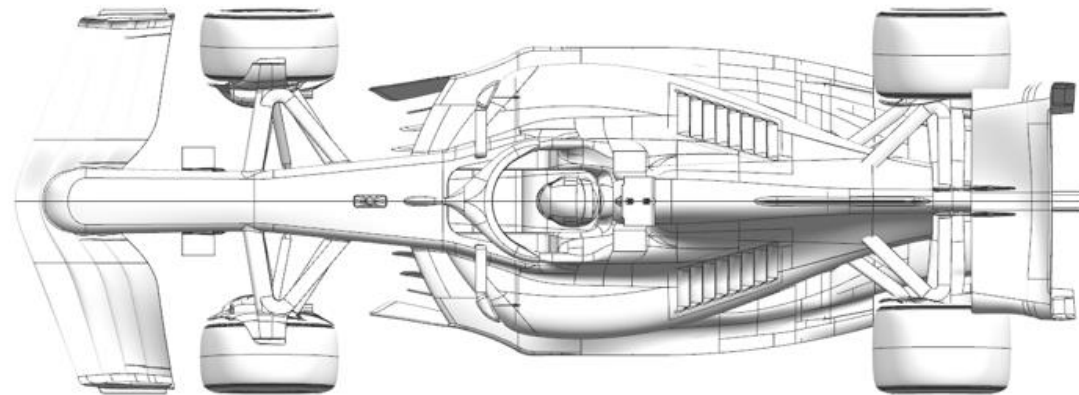
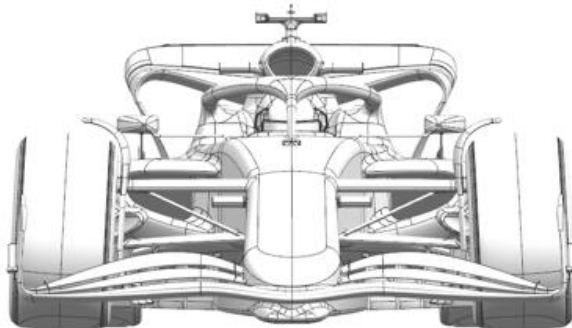
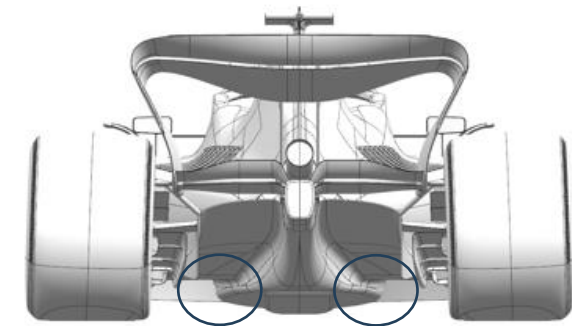



FIA FORMULA 1 WORLD CHAMPIONSHIP



**Car Presentation – Azerbaijan Grand Prix
Mercedes-AMG PETRONAS F1 Team**

No updates submitted for this event.



FIA FORMULA 1 WORLD CHAMPIONSHIP



**Car Presentation – Azerbaijan Grand Prix
Scuderia Ferrari**

No updates submitted for this event.



FIA FORMULA 1 WORLD CHAMPIONSHIP



**Car Presentation – Azerbaijan Grand Prix
McLaren Formula 1 Team**

No updates submitted for this event.



FIA FORMULA 1 WORLD CHAMPIONSHIP



Car Presentation – Azerbaijan Grand Prix Aston Martin Aramco F1 Team

	Updated component	Primary reason for update	Geometric differences compared to previous version	Brief description on how the update works (min 20, max 100 words)
1	Rear Corner	Performance - Local Load	The trim to the bottom edge of the lower deflector has been revised.	The revised lower deflector bottom edge geometry modifies the local flowfield around the rear part of the floor improving its performance.



FIA FORMULA 1 WORLD CHAMPIONSHIP

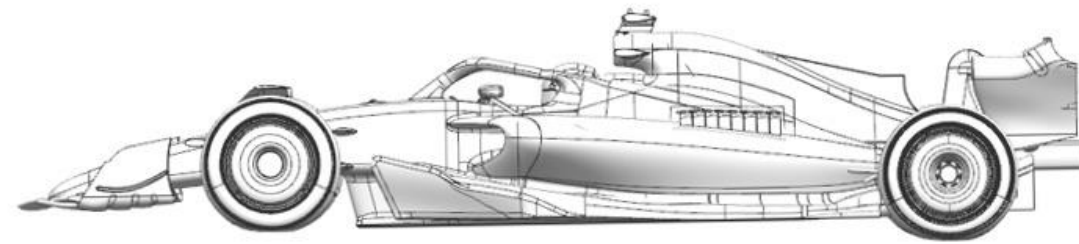
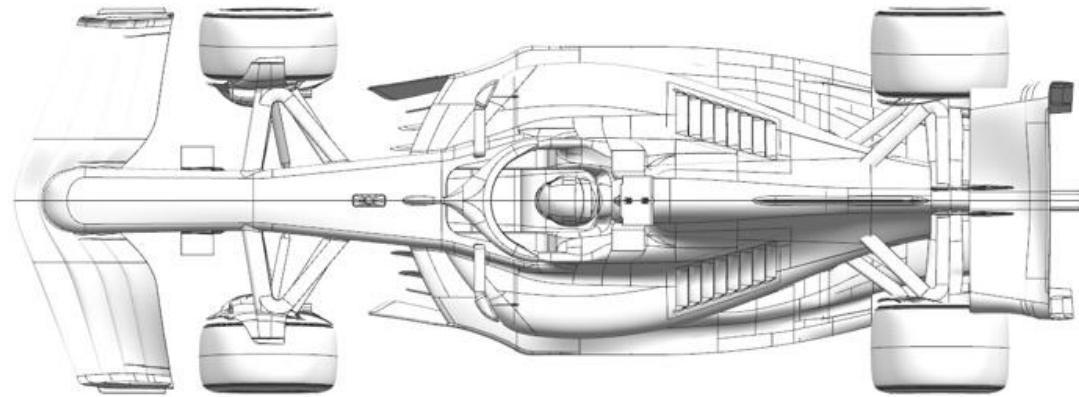
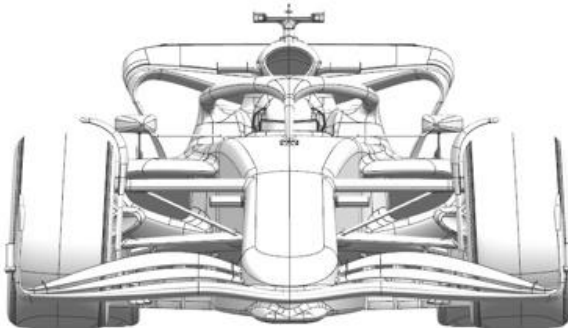
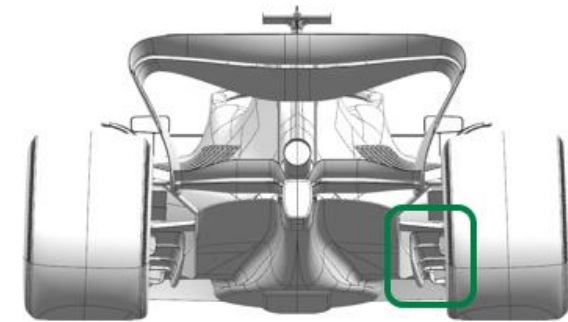



FIA FORMULA 1 WORLD CHAMPIONSHIP



**Car Presentation – Azerbaijan Grand Prix
BWT Alpine F1 Team**

No updates submitted for this event.



FIA FORMULA 1 WORLD CHAMPIONSHIP



**Car Presentation – Azerbaijan Grand Prix
Williams Racing**

No updates submitted for this event.



FIA FORMULA 1 WORLD CHAMPIONSHIP



Car Presentation – Azerbaijan Grand Prix

Visa Cash App RB

	Updated component	Primary reason for update	Geometric differences compared to previous version	Brief description on how the update works (min 20, max 100 words)
1	Front Wing	Circuit specific - Balance Range	Reduced camber flap compared to previous low-balance components.	This less cambered front flap reduces the amount of overall load generated by the front wing assembly, to efficiently balance the car at circuits which are both low-drag and low-balance.



FIA FORMULA 1 WORLD CHAMPIONSHIP

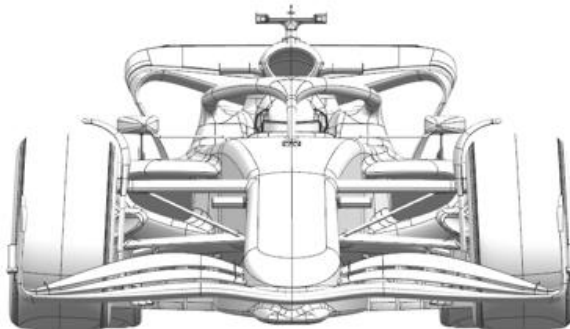
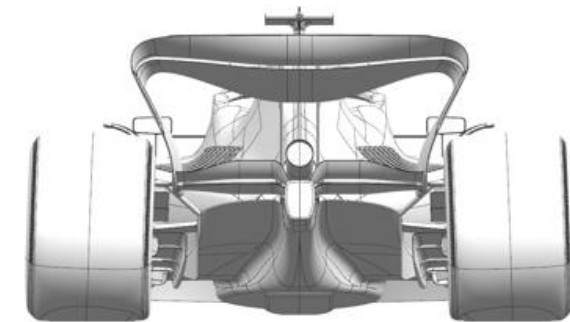

Front wing

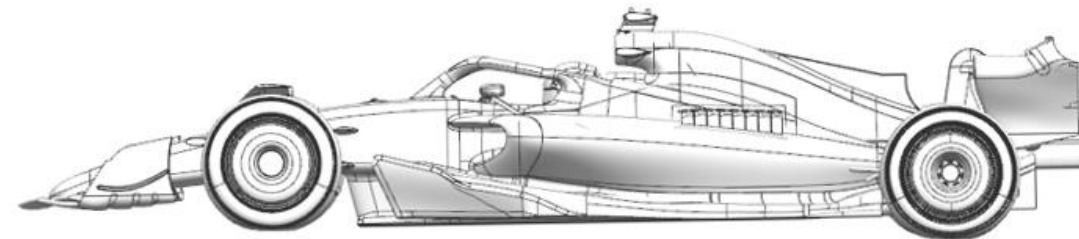
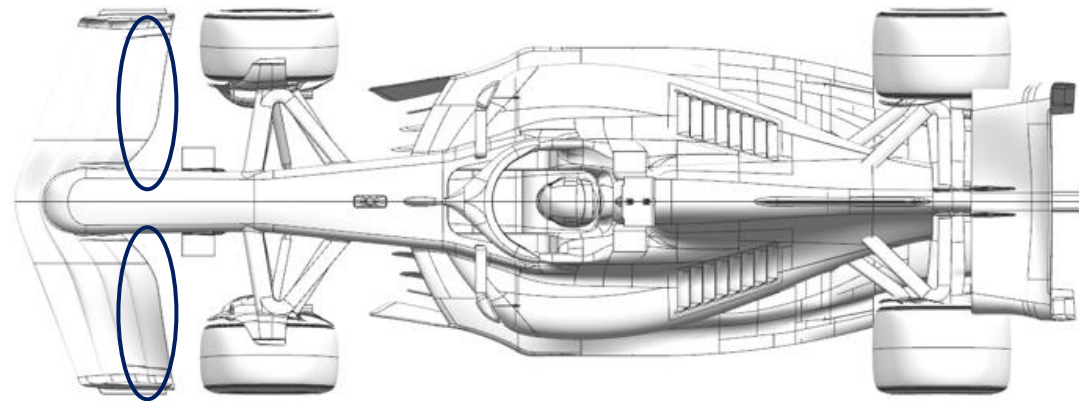



FIA FORMULA 1 WORLD CHAMPIONSHIP



**Car Presentation – Azerbaijan Grand Prix
Stake F1 Team KICK Sauber**

No updates submitted for this event.



FIA FORMULA 1 WORLD CHAMPIONSHIP



**Car Presentation – Azerbaijan Grand Prix
Moneygram Haas F1 Team**

No updates submitted for this event.